

Development of New PWR Type Transport Casks

K.Kuriyama¹⁾, K.Kawakami²⁾, T.Matsumoto³⁾, Y.Nakamura³⁾

1) Engineering Department, Nuclear Fuel Transport Co., Ltd., 1-1-3, Shiba Daimon, Minato-ku, Tokyo 105-0012, Japan

2) Design Division, OCL Corporation, New Nishishinbashi Building, 2-11-6, Nishishinbashi, Minato-ku, Tokyo 105-0003, Japan

3) Design Division, OCL Corporation Osaka Branch Office, Nakanoshima Intes, 6-2-40, Nakanoshima, Kita-ku, Osaka 530-0005, Japan

1. INTRODUCTION

NFT is doing the transport of radioactive materials such as spent fuels, low level radioactive wastes in commission by Japanese Utilities (JU) in Japan, and the design development and the manufacture of the transport casks for its purpose.

In the development of the cask for the transport of spent fuels from domestic nuclear power plants to JNFL reprocessing plant at Rokkasho, NFT has developed 4 types of NFT-type casks made of forged steel for BWR fuels, and 2 types of NFT-type casks made of multi-layered-structure with lead for PWR fuels, with different loading capacity. Up to the present, NFT has manufactured 32 BWR-type casks, and 21 PWR-type casks.

On the PWR-type cask, multi-layered-structure using lead with high gamma shielding capability has been adopted in order to contain large quantities of spent fuels with short cooling time on demand of JU. In the consideration of small storage capacity of spent fuels for some PWR Plants, the PWR-type cask has been developed as to be able to contain fuels with short cooling time. At the time of initial developing, it was judged that the production cost of the multi-layered-type cask would be almost same compared with forged steel type casks. However, in the recent procurement of casks, in fact, the cost of the multi-layered-type casks is higher than the cost of forged steel type casks. This is because that the multi-layered-type cask needs special pouring and cooling process of lead with keeping bonding lead to steel walls, which needs special technique and much experience, to obtain high performance for heat removal in order to contain fuels with short cooling time, with the result that only few manufacturers compete for the procurement of the multi-layered-type cask.

Therefore, NFT has begun to develop forged type PWR casks, because which would lead low price by competition among many suppliers on the procurement.

2. THE GOAL OF THE DEVELOPMENT

NFT has proceeded with the development of new forged type PWR casks in cooperation with OCL, to reduce the procurement price of PWR casks by stirring many suppliers up.

The basic design policy of new type casks is as follows:

- **No changes of Loading Capacity**
Because the gamma shielding performance of the forged type cask is less compared with the multi-layered-type cask, NFT has intended the new forged type PWR cask design to keep same loading capacity as former multi-layered-type cask by means of extending fuel cooling time, based on the result of simulating spent fuel pool capacity of all Japanese PWR plants.
- **No changes of handling performance at power plants and Rokkasho reprocessing plant**
The outward form and size of cask related with handling are required to be the same as the conventional PWR cask, in order to not require additional handling tools at power plants and Rokkasho reprocessing plant. **Fig.1** shows the comparison between shielding structures of the conventional multi-layered-type cask (NFT-14P) and the new forged steel type cask (NFT-14P-A). Regarding the design of NFT-14P-A cask, the thickness of resin and main body wall, and the cooling time of spent fuels have been optimised, keeping same inner and outer diameters of the cask, in consideration of the decrease of gamma shielding performance compared with the use of lead.

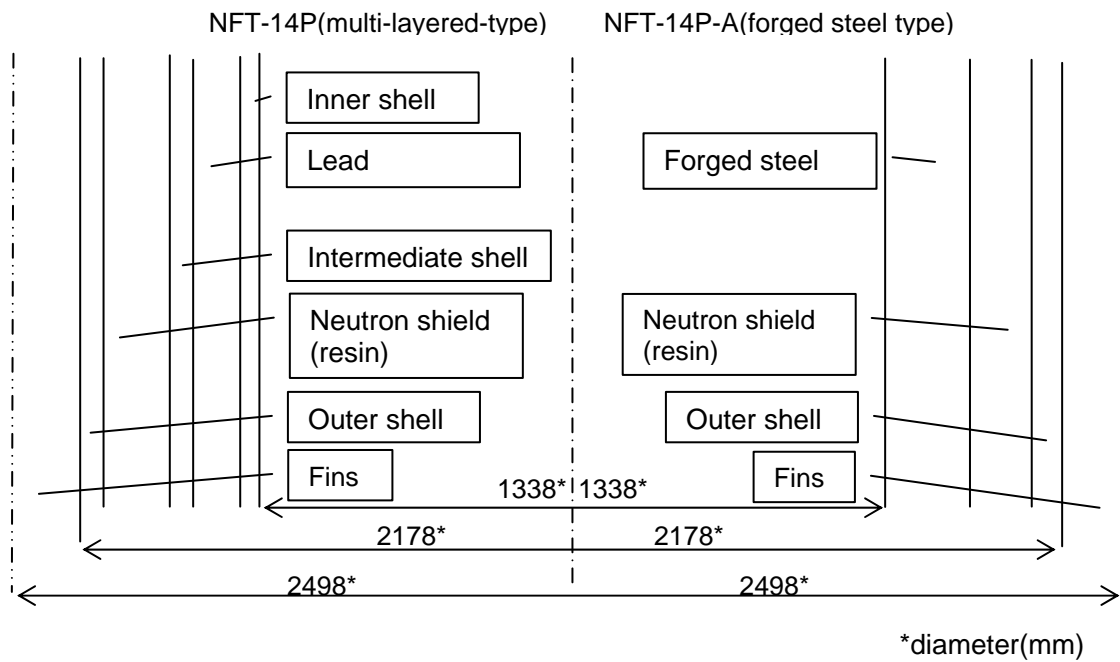

Fig.1 Comparison between Shielding Structures

- **Make it possible to transport damaged fuel**

As shown in **Fig.2**, the new NFT-14P-A type cask has a basket can contain 14 PWR fuel assemblies, and the one compartment located at the lower part of the basket is bigger for the insertion of damaged fuel can. Though the new basket configuration is basically same to that of NFT-14P, the compartment arrangement is optimised in order to make one large compartment, and to keep good performance for subcriticality control.

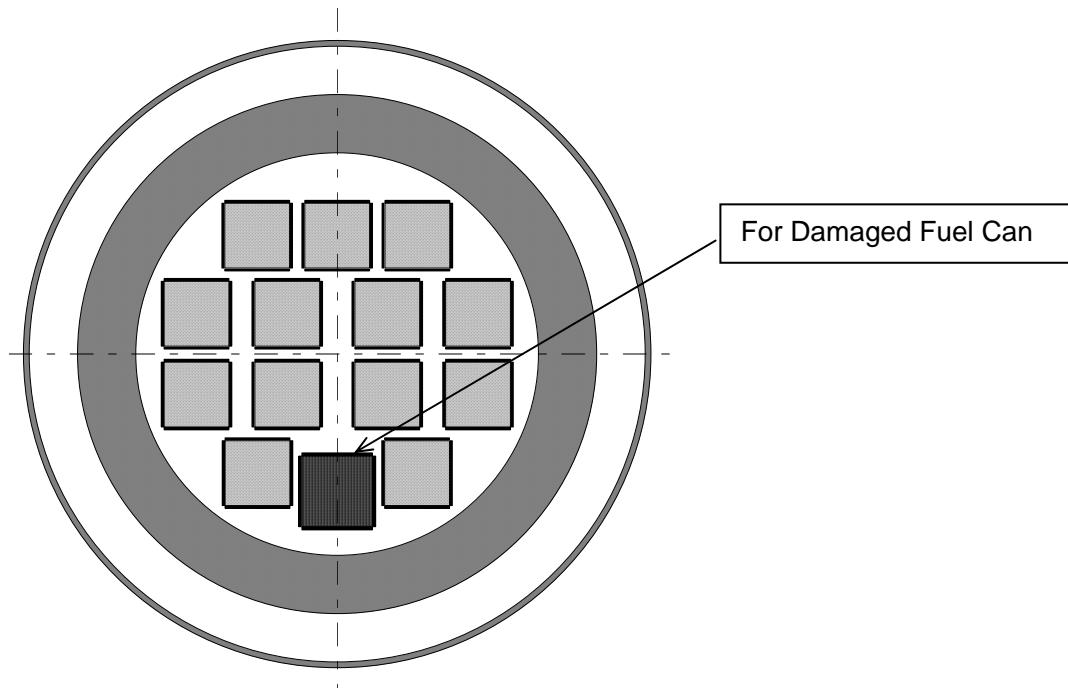

Fig.2 Basket Design to Contain a Can for Damaged Fuel

- **Improve decontaminating performance for outer shell**

By taking advantage of reduction of heat load followed extending cooling time, the number of outer heat removal fins can be reduced. In the result, the gap space between fins is widened as shown in **Fig.3**, and it makes easier to access to the surface of outer shell to do decontamination works.

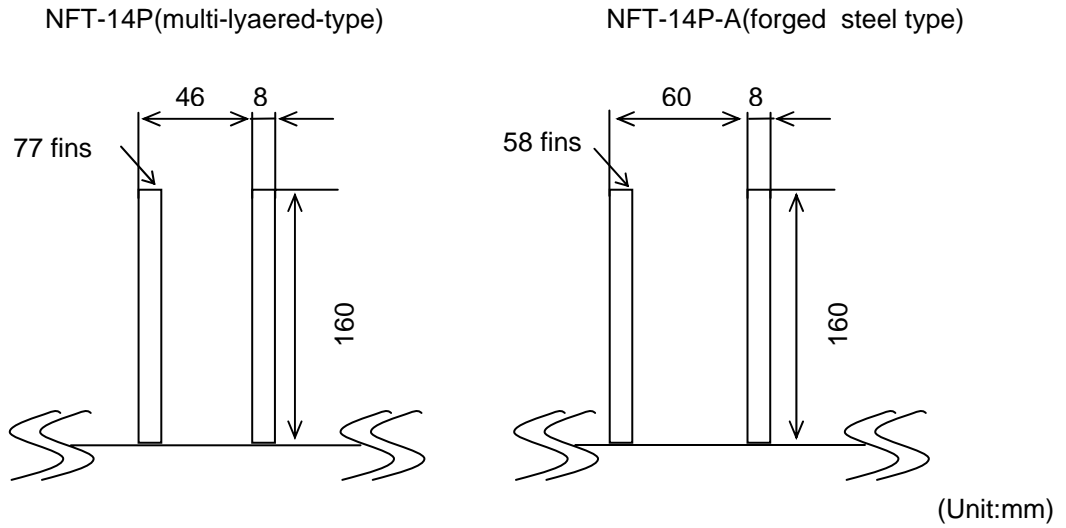

Fig.3 Change of Interval of Heat Removal fins

3. THE OUTLINES OF NEW NFT-PWR TYPE CASK

As shown in **Fig.4**, the new NFT-PWR type cask (NFT-14P-A type cask) is constructed of a cask body, a lid, a basket and shock absorbers. The cask body consists of main steel body, neutron shield and heat transfer fins.

Table.1 shows outlines of NFT-14P-A design compared with conventional multi-layered type Cask (NFT-14P). The conditions of contents for NFT-14P-A are the same for NFT-14P type cask except cooling time.

Table.2 shows the comparison of shielding performance of NFT-14P-A and NFT-14P. The extension of cooling time for contents of NFT-14P-A compensates the reduction of the gamma shield. And also, the neutron shielding performance is maintained as much as possible by increasing steel wall thickness despite the fact that the resin neutron shield thickness is decreased. In results, this new design can adopt to increasing burn-up of contents in the future.

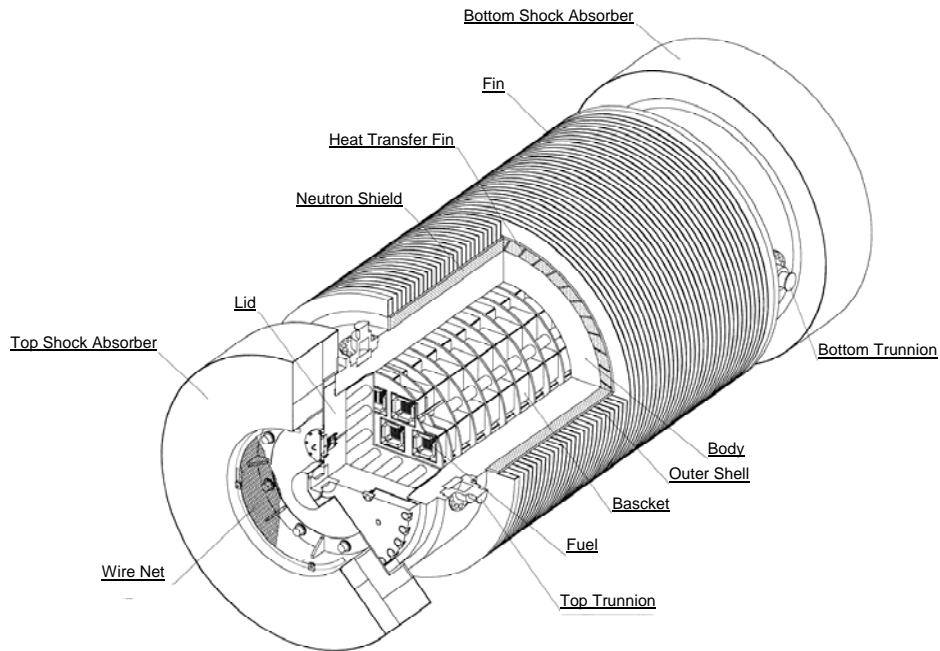

Fig.4 Overview of NFT-14P-A Cask

Table.1 Outlines of NFT-14P-A Design compared with Conventional Multi-Layered Type Cask

	Multi-Layered type NFT-14P	New Forged type NFT-14P-A
No. of Fuel Assemblies	14	14
Max. Burnup (Ave. of Contents) (Max. of Contents)	44 GWD/MTU 48 GWD/MTU	44 GWD/MTU 48 GWD/MTU
Max. Initial Enrichment	4.3 wt% U-235	4.3 wt% U-235
Max. Heat Load	54 kW	35 kW
Min. Cooling Time	630 days	990 days

Table.2 The Comparison between Shielding Performance of NFT-14P-A and NFT-14P

Location			Dose Rate (μ Sv/h)				
			Neutrons	Fuel Gammas	Gammas from Fuel Hardware Activation	Secondary Gammas Generated by Neutron Capture	Totals
NFT-14P-A	External Surface of Package	Side	15	112	12	2	141
	At 1-Meter from External Surface		9	51	6	1	67
NFT-14P	External Surface of Package	Side	20	114	9	4	147
	At 1-Meter from External Surface		9	52	4	2	67

4. COST MERIT OF INTRODUCING NFT-14P-A TYPE CASK

NFT has currently numbers of casks that are necessary to transport spent fuels of 400 to 500 tU/year, and is planning to increase quantity of transportation of spent fuels up to 800 tU/year. For that purpose, it is necessary to procure additional casks. The cost evaluation has been carried out in the case of introduction of the new NFT-14P-A type cask. The result is that the annual transportation cost will be able to be reduced by 1%, assuming that all procured casks are NFT-14P-A type cask.

5. CONCLUSION

NFT and OCL have developed new NFT-14P-A type cask for the transportation of PWR spent fuels, and confirmed safety performance of the cask. This new cask will lead to getting cost merit, spreading uses and good maintenance performance as follows:

- The new NFT-14P-A type cask has been developed as forged type PWR casks, because which would lead low price by competition among many suppliers on the procurement. And the outward form and size of cask related with handling is the same as the conventional PWR cask, in order to not require additional handling tools at power plants and Rokkasho reprocessing plant.
- The new NFT-14P-A type cask can contain a damaged fuel can.
- Because that the gap space between outer heat removal fins is widened, it makes easier to access to the surface of outer shell to do decontamination works.